

# HCV

Mechanical Seal **6D Cartridge** Ball Valves

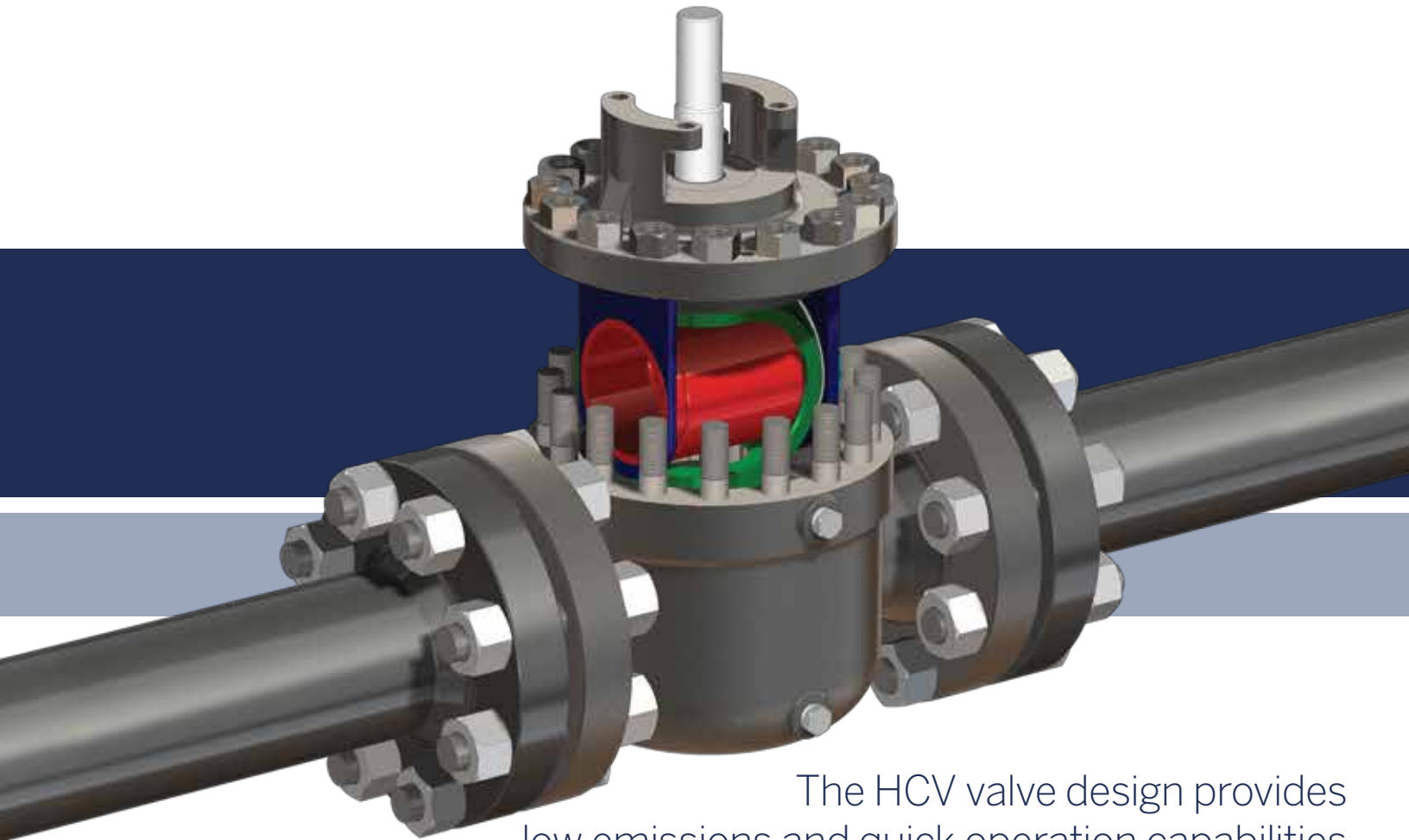

The HCV valve design provides low emissions and quick operation capabilities in critical shutoff applications and severe services.

■ **Advanced Design**

- Incorporates the positive features of ball, gate, plug and high performance valves

■ **Versatile**

- The HCV valve is a quarter turn, mechanically sealing, through conduit, tight shutoff valve that is well suited for a broad range of applications

# INTRODUCTION

The HCV valve is an advanced design that incorporates the positive features of ball, gate, plug and high performance valves. The HCV valve is a quarter turn, mechanically sealing, through conduit, tight shutoff valve that is well suited for a broad range of applications. It is innovative and effective with minimal maintenance required.

The HCV valve design provides low emissions and quick operation capabilities in critical shutoff applications and severe services. The unique stationary core design improves the flow characteristic and protects the body and seat from erosion. The metal seated valve uses the same body and bonnet as the resilient seated valve and is factory tested to the tightest leakage criteria in the industry.

The HCV valve is manufactured by Chromatic Industries LLC at 16400 Air Center Blvd, Suite 200, Houston TX 77032. The HCV valve is available in a range of materials of construction including various carbon and alloy steels, as well as high grade stainless steels, duplex stainless steels, and high nickel/chrome alloys for various services in critical oil and gas applications.



# HCV VALVE

The HCV valve represents the newest, most innovative combination of the best characteristics of the major valve designs (Ball, Gate, and Triple Offset/Butterfly valves) with superior advantages of access and reparability of sealing components.

## BUBBLE TIGHT – DROP TIGHT SEALING

The HCV valve can be supplied with either resilient or metal seats to hold to the tightest of industries standards. The resilient seated valves are tested to bubble tight requirements (API 6D/ISO 5208 Rate A with no visible leakage allowed) and the metal seated valves are tested to drop tight standards (ISO 5208 Rate D).

## BALL VALVE CHARACTERISTICS

The HCV valve is manufactured to ASME B16.10 ball valve end to end dimensions. It is a direct replacement - flange to flange - of most standard ball valves. It is easily actuated with a simple, quarter-turn operation.

## GATE VALVE CHARACTERISTICS

The closing member (*HEMI*) cuts through the media stream similar to a gate valve, reducing turbulence/cavitation normally experienced in ball valve designs, providing a more uniform/fluid flow of media.

## TRIPLE-OFFSET VALVE CHARACTERISTICS

Mechanical -Dynamic Seating: As the valve closes the *HEMI* provides mechanical sealing as a result of implementing a wedge in the *HEMI*. As the *HEMI* rotates from open position to closed position, an increased offset applies its own force, independent of line pressure, to affect a positive seal.

Modulating Flow: The *HEMI* can be supplied with a characterized orifice (V-notch) to provide flow control. The combination of a stationary core maintaining linear flow through the valve and the modified *HEMI* can provide repeatable throttling without damaging the seats.

## FIRE-SAFE

The HCV valve is inherently fire-safe and has been tested and passed the latest ISO 10497 and API 607 requirements.

## TOP ENTRY – CARTRIDGE VALVE

The HCV valve's cartridge feature provides ease of access to internals for simple, quick repair or re-trim. All internal parts are attached to the bonnet allowing quick exchange when required, minimizing downtime.

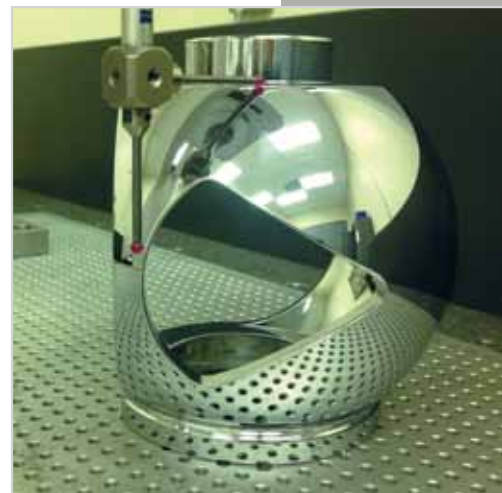

## FEATURES

### CARTRIDGE DESIGN

- Top Entry
- Ease of Repair
- Reduced Downtime
- Serialized Cartridges
- Interchangeability

### MECHANICALLY SEATED

- **HEMI** - Mechanical Wedge
- Bubble Tight Seating
- Bi-Directional Sealing
- Seals without use of springs or pressure differential

### STATIONARY CORE

- Minimizes direct flow into the seat
- Linear Flow Characteristic
- Reduced Turbulence and velocity

### QUARTER TURN OPERATION

- Easily and Economically Automated
- Quick / Reliable Operation
- Low Dimensional Profile

## HCV CARTRIDGE VALVE

### CARTRIDGE DESIGN

The HCV's defining feature is its '*cartridge design*' whereby all the valve's internal sealing parts are affixed to the bonnet allowing quick and easy serviceability and reducing expensive downtime during maintenance.

This 'cartridge design' provides the ability to repair the valve with relative ease in a minimum amount of time without any special training or special tools.

When the valve is isolated (de-pressured), simply remove the bonnet fasteners, slide the cartridge out of the body, insert the new cartridge into the body, and retighten the bonnet fasteners.

Patents: 7,357,145; 7,484,523; 7,836,909; 8,308,132.

Numerous patents pending in USA and worldwide.

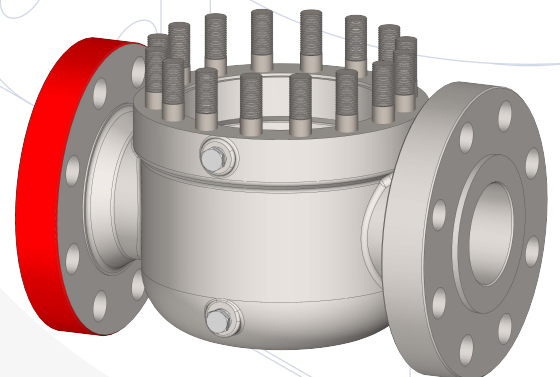
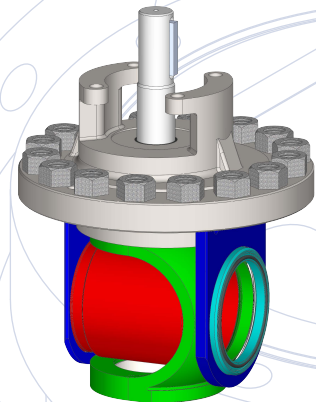
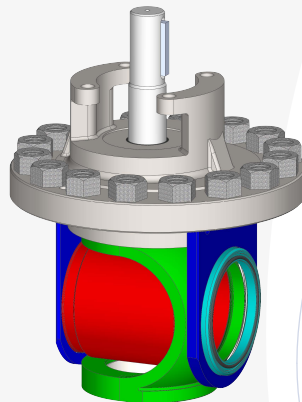

## MECHANICAL WEDGE SEATING

The mechanical seal is achieved by rotating the **HEMI** around a central fixed point (stem). The increased offset of the external sealing surface of the **HEMI** creates a positive mechanical load on the seat at the full closed position. The positive mechanical load provides a tight seal at both low and high pressures irrespective of direction of differential pressure.

CORE

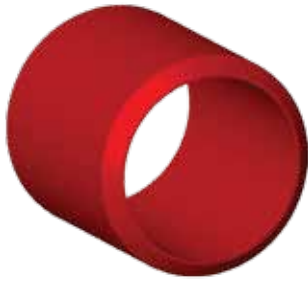

HEMI



CORE/HEMI/SEAT

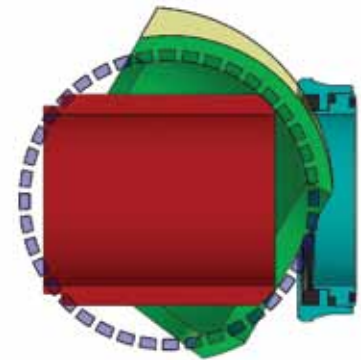

## STATIONARY CORE

Throughout the opening and closing of the valve, the core (red) maintains its stationary position within the **HEMI** (green), which directs fluid flow straight through the valve with minimal impingement of the seat ring or side of the body. This results in less erosion in the valve body and longer seat life compared to conventional ball valves, particularly with flow streams containing scale, sand, and other particulates.

FULL OPEN

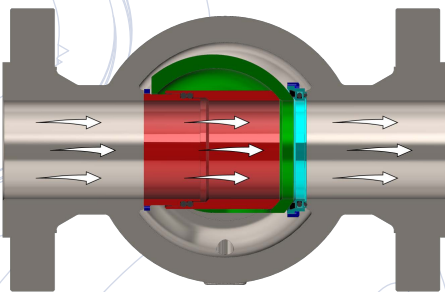

HALF OPEN

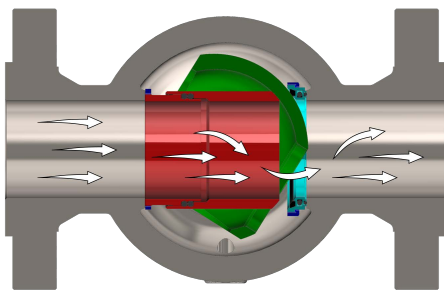

FULL CLOSED

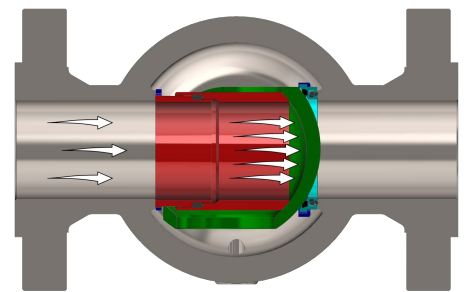

### BALL VALVE FLOW COMPARISON

The ball valve below in the half open position directing damaging flow at the seat sealing surface.

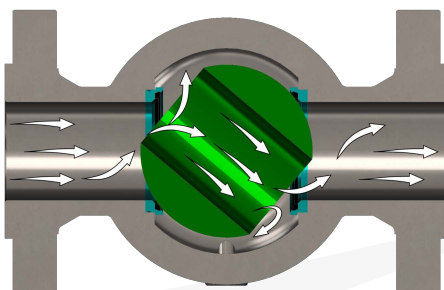

HCV valves are available in a variety of sizes, pressure classes, materials, and trims. The basic design is easily scalable. Additional sizes, pressures classes and features are continually under development to meet industry needs.

**MATERIAL AVAILABILITY**

Carbon steel (A216 Grade WCC), impact-tested carbon steel (A352 Grade LCC), and stainless steel (A351 Grade CF8M) are the most typical alloys offered, but other alloys are available for body/bonnet or internals depending on service conditions. Trim materials are available in a variety of alloys to meet NACE requirements and other corrosive environments.

**SEATS/SEALS**

The selection of seat/seal material is dependent on the service fluid and temperature, and includes various common elastomers such as Viton® and HNBR, or synthetic materials such as Teflon®, Tefzel®, PEEK, or all-metal. The core design provides protection of the seat face resulting in longer sealing capability.

**PRODUCT AVAILABILITY**

HCV valves are available in either Full or Reduced Port configurations with most common end connections including raised face, ring type joint, butt-weld, threaded. Special sizes and design modifications can be discussed for special applications.

# PRODUCT AVAILABILITY

**Standard Materials of Construction**

1	<b>Body</b>	ASTM A216-WCC; ASTM A351-CF8M
2	<b>Bonnet</b>	ASTM A216-WCC; ASTM A351-CF8M
3	<b>Stem</b>	ASTM 4140 CS ENP; 17-4 SS or Nitronic 50 SS
4	<b>HEMI</b>	Carbon Steel ENP or QPQ; Stainless Steel
5	<b>Core</b>	Carbon Steel ENP or QPQ; Stainless Steel
6	<b>Seat</b>	Carbon Steel ENP; Stainless Steel
7	<b>Seat Insert</b>	Teflon; Nylon; PEEK
8	<b>Seals</b>	Viton; HNBR; FFKM
9	<b>Retaining Plates</b>	Carbon Steel ENP; Stainless Steel
10	<b>Screws</b>	ASTM A573
11	<b>Bonnet Fasteners</b>	ASTM A193-B7 / A194-2H

*HCV valves can be trimmed to meet a range of applications including sour corrosive services requiring NACE compliant materials.*

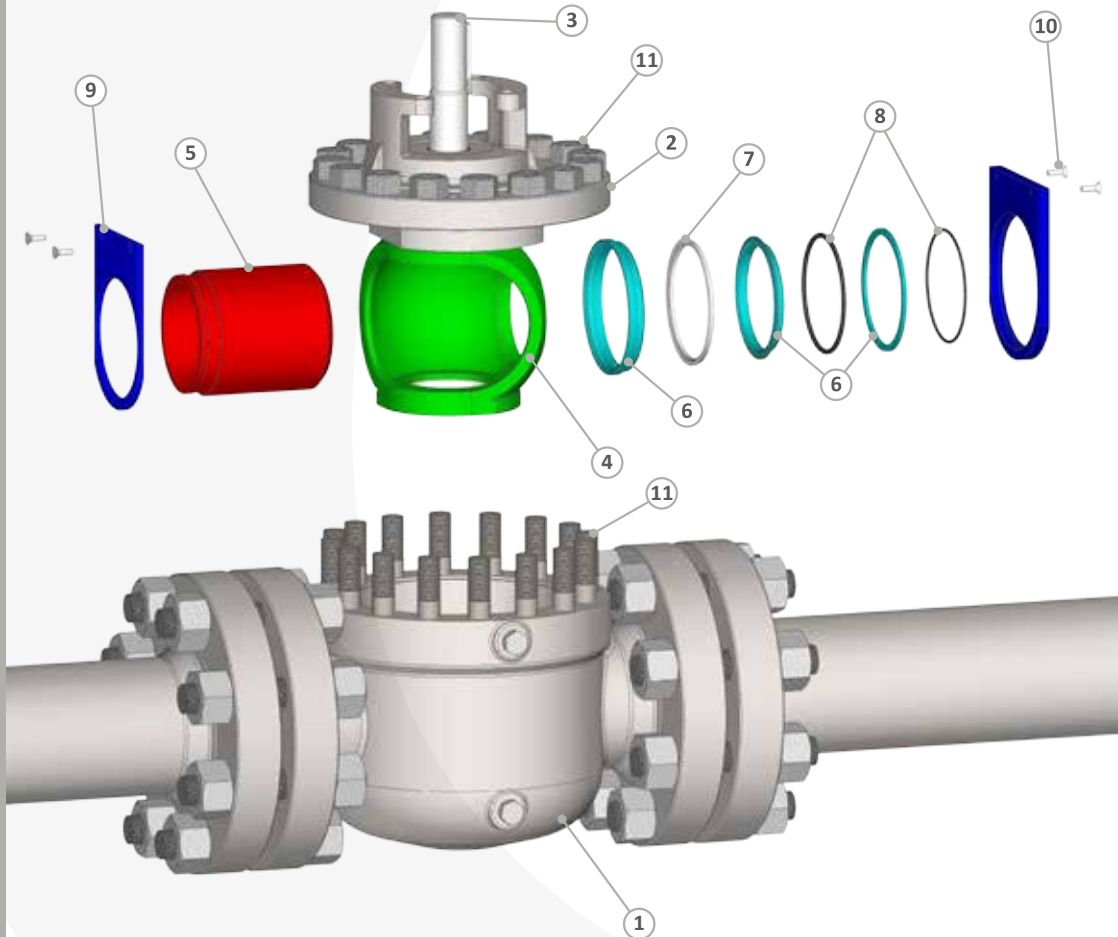

# APPLICATIONS

## *Proven Successes and Creative Solutions*

### **ISOLATION/BLOCK VALVE**

For critical isolation requirements demanding bubble tight shut-off.

### **DOUBLE BLOCK AND BLEED VALVE (DBB)**

To provide verification of valve sealing and ensure seat integrity.

### **ESD (EMERGENCY SHUT DOWN) VALVE**

In the case of an emergency, the HCV valves can provide a reliable quarter-turn operation with a repeatable, mechanical “zero leakage” shut-off.

### **BRINE/STORAGE BLOCK VALVE**

Application where corrosive salt water is always present and salt crystal buildup can make a valve difficult to perform. The proven HCV valves can break through salt formation; HEM-Core design help protect the seats and body from erosion corrosion; and the mechanical sealing delivers repeatable shutoff.

### **MOLECULAR SIEVE SWITCHING/BLOCK VALVE**

Constant temperature swings up to 600 F and cycling of the valve create a demanding environment for a valve. The Core and **HEMI** combine to protect the seat from desiccant particles. For frequent cycling in high temperature cyclical environments involving potential damaging solids (dust).

### **MODULATION/THROTTLING VALVE**

The combination of a characterized **HEMI** (reducing turbulence) and the stationary core (straightening vane) the HCV valves can provide dependable modulating service.

### **EXTENDED BODY (FOR BURIED SERVICE) VALVE**

The body can be extended for buried service so the internals can be accessed from the surface eliminating the requirement to excavate buried valves.

### **NACE SOUR CORROSIVE BLOCK VALVE**

The HCV valves are easily trimmed for services requiring metallurgy and seals suitable for NACE services.

### **OTHER POSSIBILITIES INCLUDE:**

- Blow-Down Valves
- Meter / Prover (DBB) Block Valve
- Kicker Valves
- Pig Launcher / Receiver Valves



*Let Us Help You in Your Demanding Applications*

## Why Chromatic?

- Engineered valve solutions that reduce downtime & operating costs
- Proven designs and experienced manufacturing capabilities
- Demonstrated innovation and technical leadership
- Technical alliances that deliver best-in-class options
- Customer satisfaction through operational excellence

**CHROMATIC** is a premier designer, manufacturer, fabricator and distributor of valve, actuation and pressure and well control products and services for the North American energy industry. The Company's 60,000 square foot headquarters and technology center is located in Houston, TX and houses fully equipped engineering, manufacturing, fabrication, and service functions. A 30,000 square foot facility in Jennings, LA, houses the Company's ChromeDRILL, ChromeLEASE and ChromeSERVE operations. We are committed to continuously improving our products and services while we strive to protect our employees, our communities and the environment.



[www.chromaticindustries.com](http://www.chromaticindustries.com)

**Chromatic Industries, LLC** / 16400 Air Center Blvd, Suite 200, Houston, TX 77032 / T: 936.539.5770

**ChromeDRILL Facility** / 1927 Hwy 90 West, Jennings, LA 70546 / T: 337.616.3300

CHROMATIC and ChromeADD are trademarks of Chromatic Industries, LLC.  
ChromeDRILL, ChromeLEASE and ChromeSERVE are trademarks of Chromatic Oil Tools, LLC (formerly Quality Oil Tools)  
CML 0002 08-2020A / Copyright © 2020 Chromatic Industries LLC. All rights reserved. / Specifications May Change Without Notice.



6A-2094  
16C-0454  
16A-0555  
17D-0202  
6D-1657